

# Experience with Cryofurnaces at ORNL

## 5<sup>th</sup> International Workshop on Sample Environment at Neutron Scattering Facilities

May 26-28, 2008

Grenoble, France

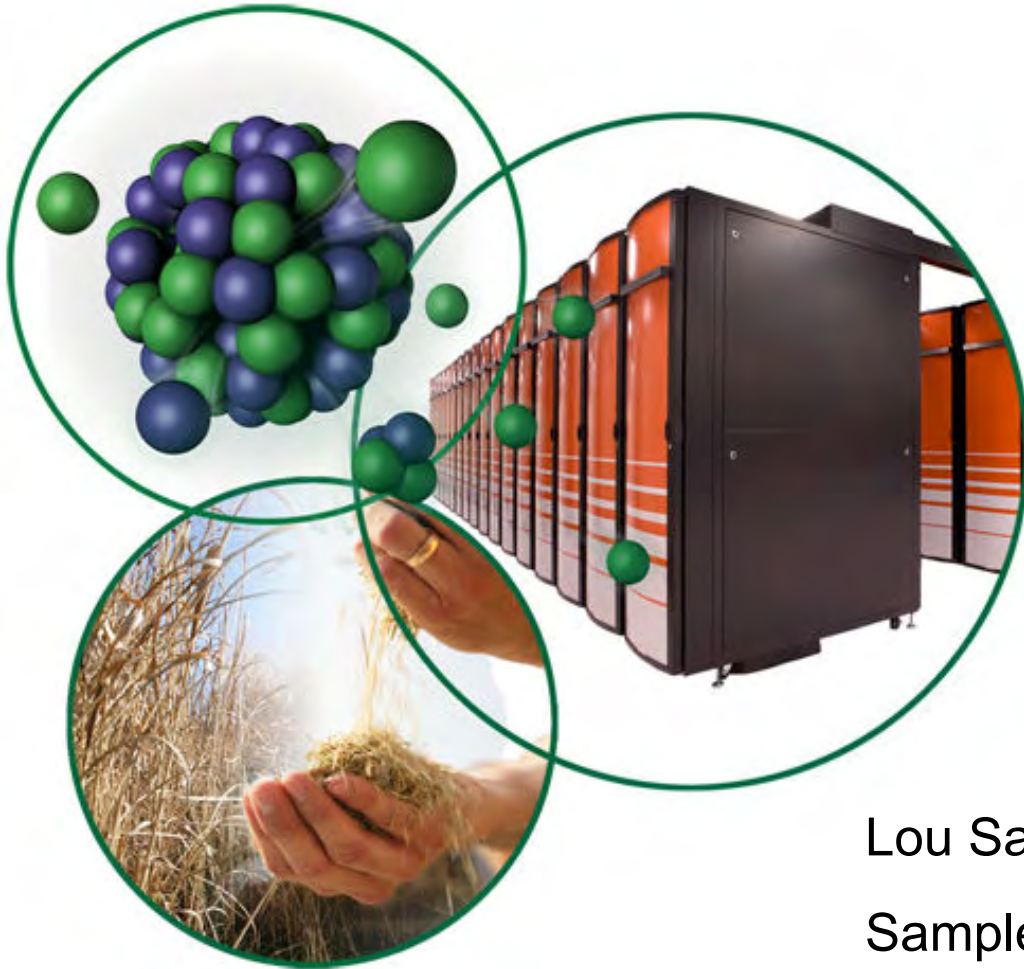

Lou Santodonato

Sample Environment Group Leader

NSSD, Oak Ridge National Lab

# ORNL Neutron Scattering Facilities

## SNS and HFIR

- SNS construction completed May 2006, user ops December 2007
- SNS achieved ~ 400 kWatt sustained beam power – most powerful pulsed spallation source
- 3 SNS operational instruments
- 3 SNS commissioning instruments
- HFIR cold source operational May 2007 (one of the brightest in the world)
- 6 HFIR operational instruments



# Oak Ridge Sample Environment Group

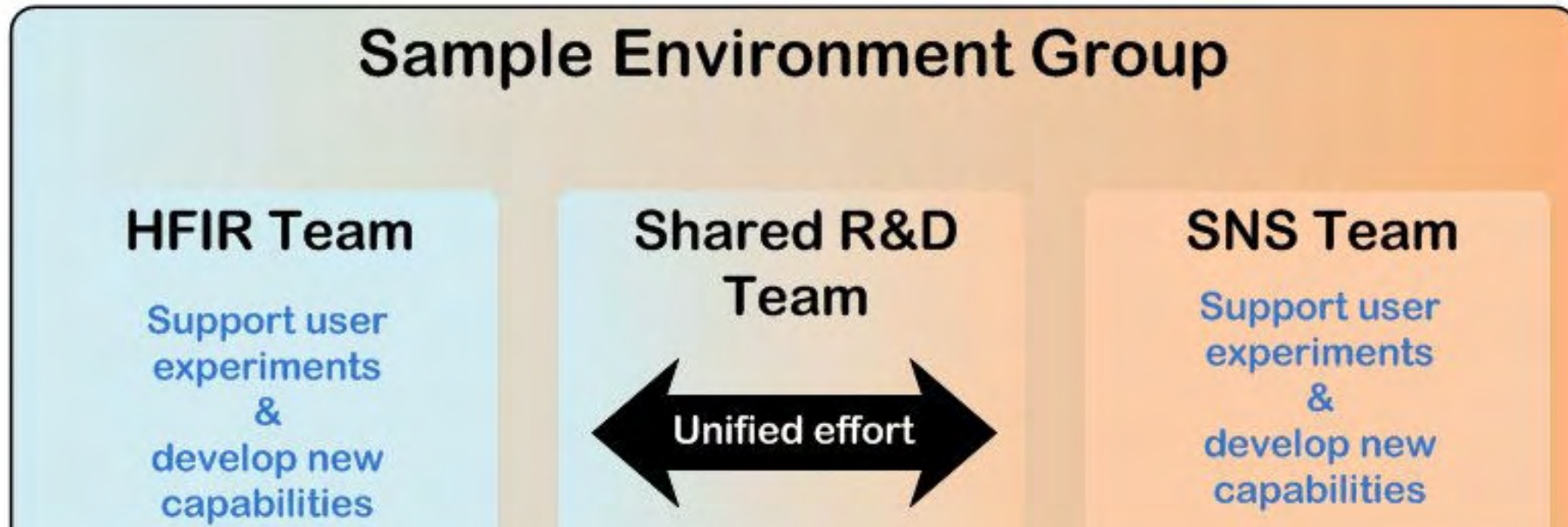

# People

## Oak Ridge Sample Environment Group

L. Santodonato – Group Leader

B. Hill – Facility Interface

### HFIR Team

C. Redmon – Team Leader

D. Reass  
J. Smith  
New Tech

### Shared R&D

L. Walker  
J. Wenzel  
L. Solomon

### SNS Team

A. Church – Team Leader

R. McPherson  
S. Elorfi  
R. Mills  
M. Collins



# Cryofurnaces at Oak Ridge

Wet

A.S. Sci.  
ILL/Orange

Hot VTI



JANIS

Hot Stick

Cold VTI



Dry

SNS

Hot VTI

Do-it-yourself  
prototype



ARS

Hot stage

Displex



# Cryofurnace Outline

- **General considerations**
- **Four different designs**
- **Test data**
- **Summary**

# General Considerations

- **How much demand?**

- Roughly 20% cryofurnace
- Based upon limited web survey

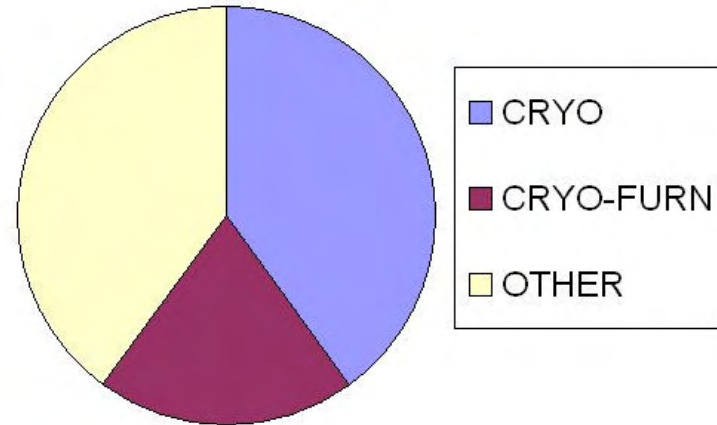

- **What temperature range?**

- Moderate range serves many
- Others want great base temp
- Can one device do it all?

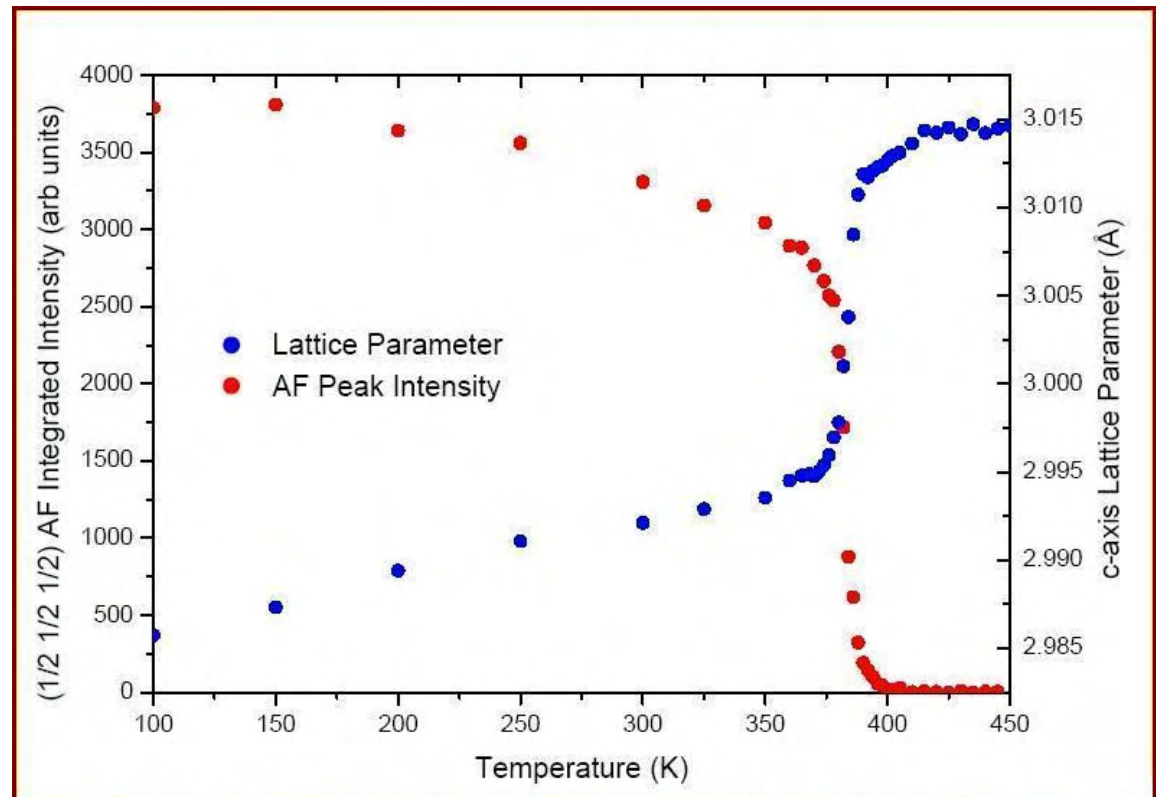

Experimental results using SNS cryo/furnace at HFIR (courtesy of J. L. Robertson)

# General Considerations

- **Instrument geometry**
  - Tanks and tables
- **Facility logistics**
  - Changing SE equipment much harder than changing sample only
- **Do-It-Yourself vs. Vendor-Supplied**

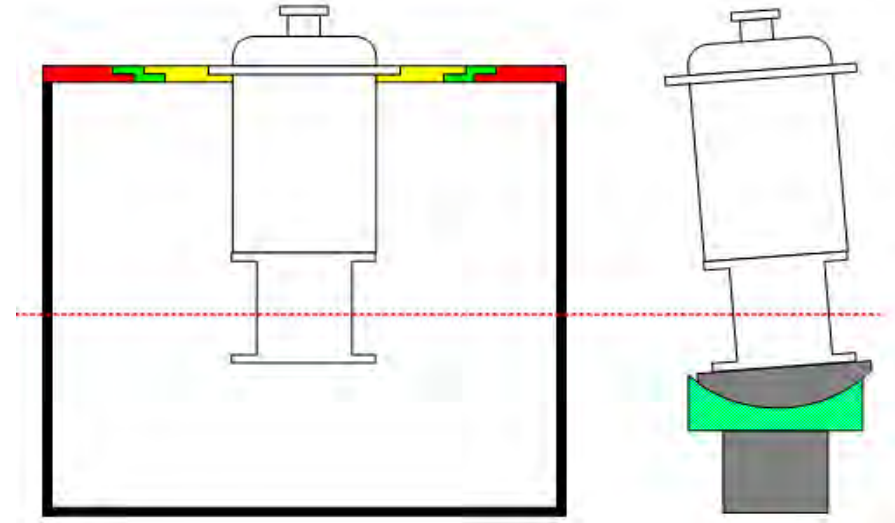



# Design 1 – Hot Stick Cryostat

- Operate as exchange gas cryostat 300K to base
- Evacuate VTI and heat stick for high temperature
- Pros
  - Adapt any top loading cryostat
  - Easy sample change
- Cons
  - Two operating modes
  - Potential for gradients
  - It's cheating!

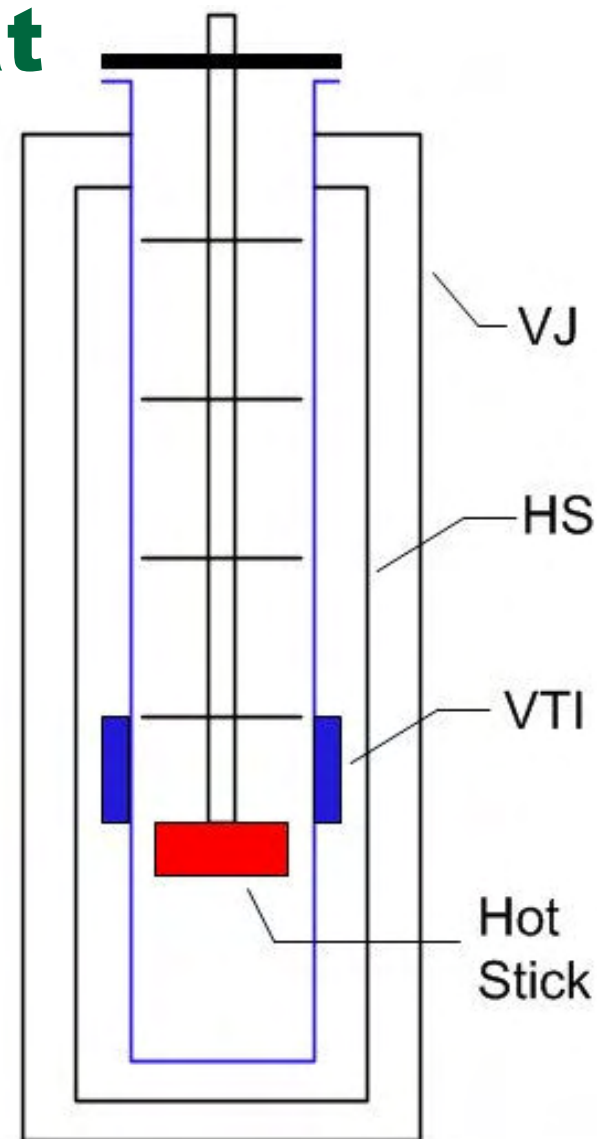

Vacuum jacket – VJ

Heat Shield - HS

Cryogenic variable temperature insert (VTI)

# Janis Hot Stick Cryostat

Manufacturer: JANIS Research

Range: 1.7 K to 600 K

Thermometry: Cernox resistor on VTI  
type-E T/C on hot stick

Sample Space: 60 mm well

## ORNL Experience

2004 Debug & commission at HFIR  
Useful, but difficult to operate



**Early testing**

# Janis Hot Stick Cryostat

Manufacturer: JANIS Research

Range: 1.7 K to 600 K

Thermometry: Cernox resistor on VTI  
type-E T/C on hot stick

Sample Space: 60 mm well

## ORNL Experience

- 2004 Debug & commission at HFIR  
Useful, but difficult to operate
- 2006 Auto exchange gas and cold valve  
commissioned at SNS
- 2008 Essential part of inventory – ever  
improving – also used with 3He  
insert

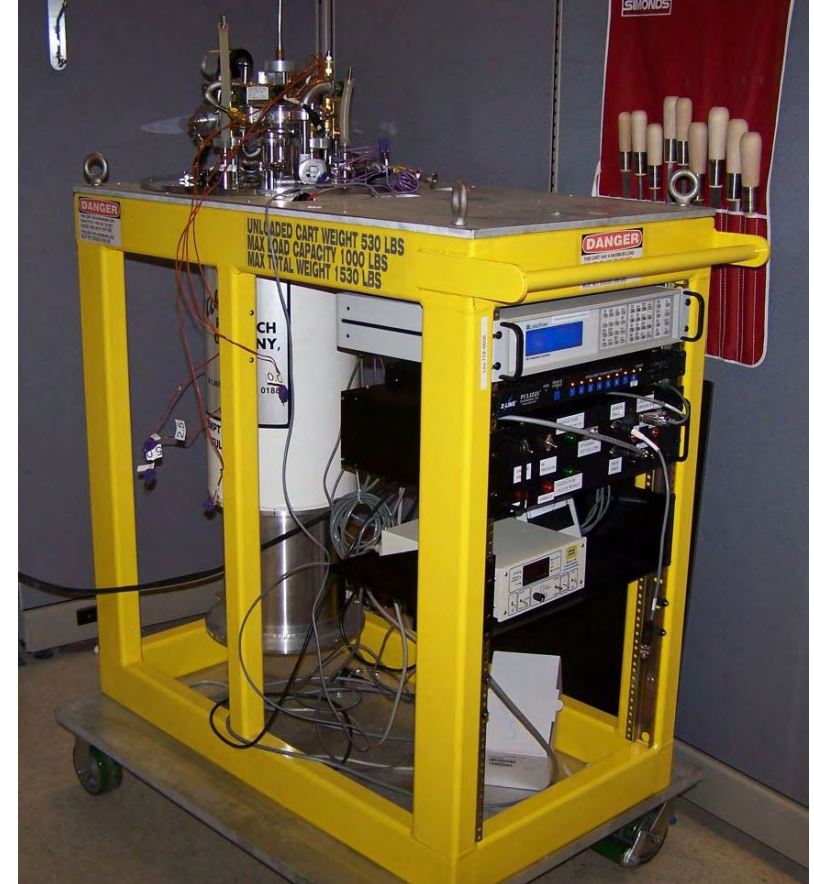

## JANIS Cryo-cart

With off-the-shelf and do-it-yourself  
automation controls

# Janis Hot Stick Cryostat: Test Data

Control-on-VTI is slow

Control-on-stick seems best for temperatures above 50 K

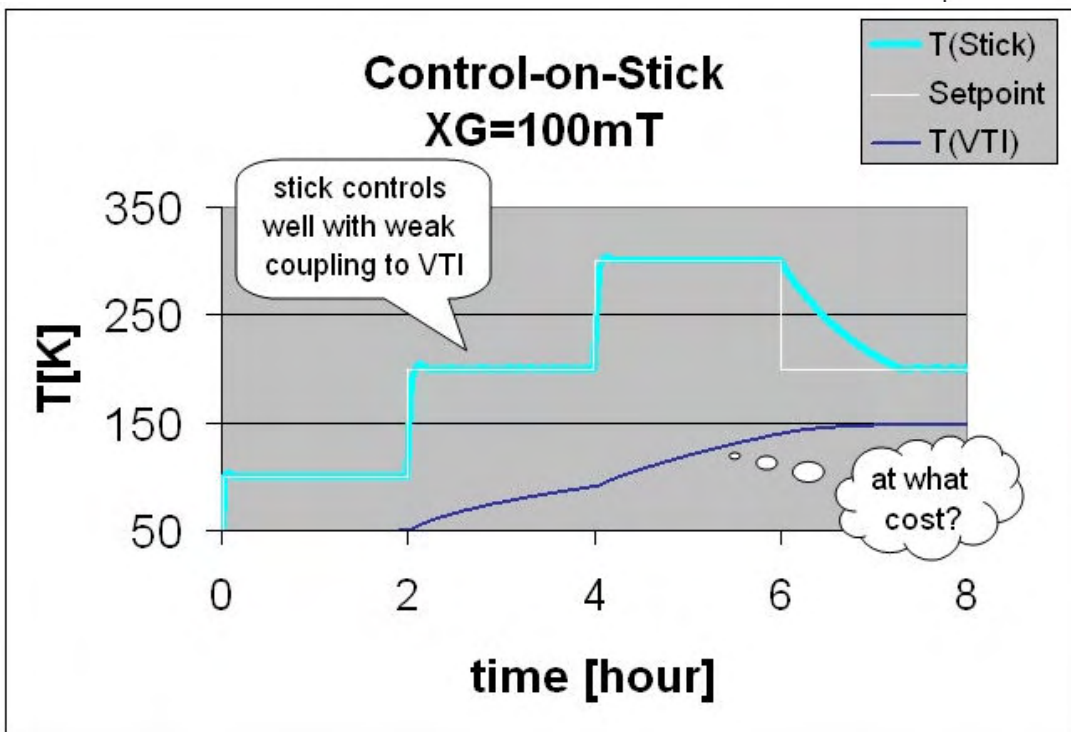
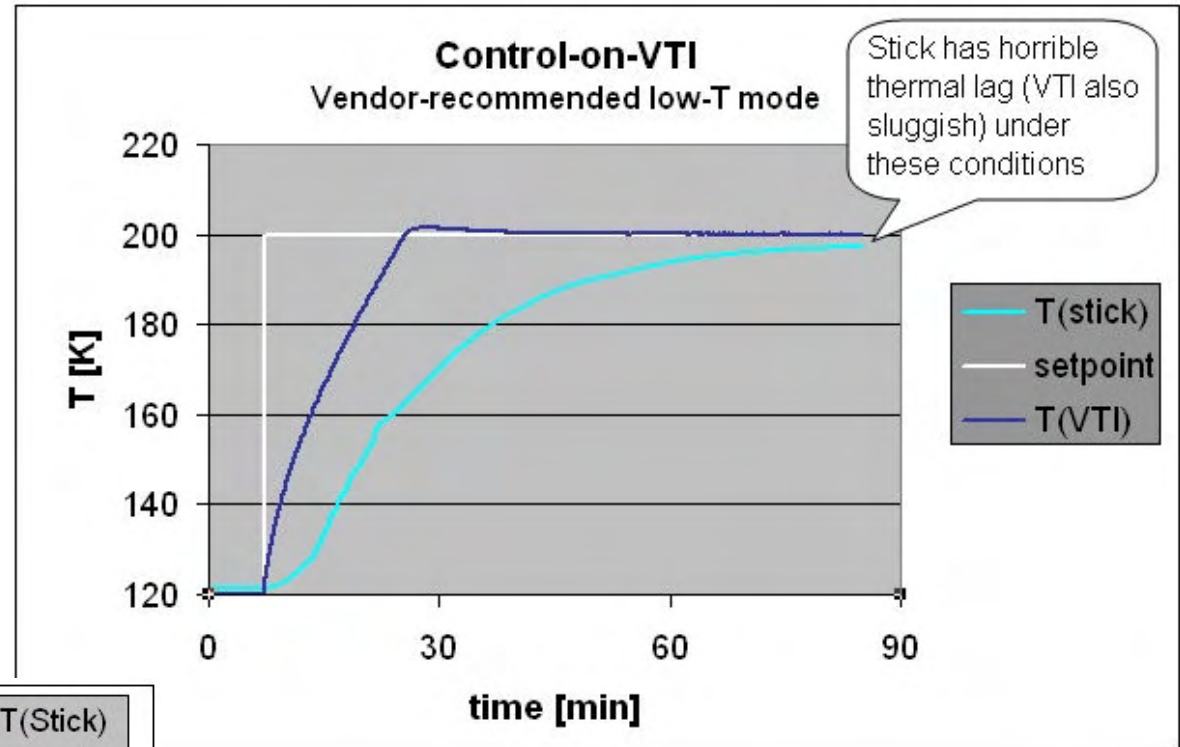

But we are concerned about temperature gradients

# Janis Hot Stick Cryostat: Test Data

- Measure top and bottom of sample
- Shielded versus unshielded

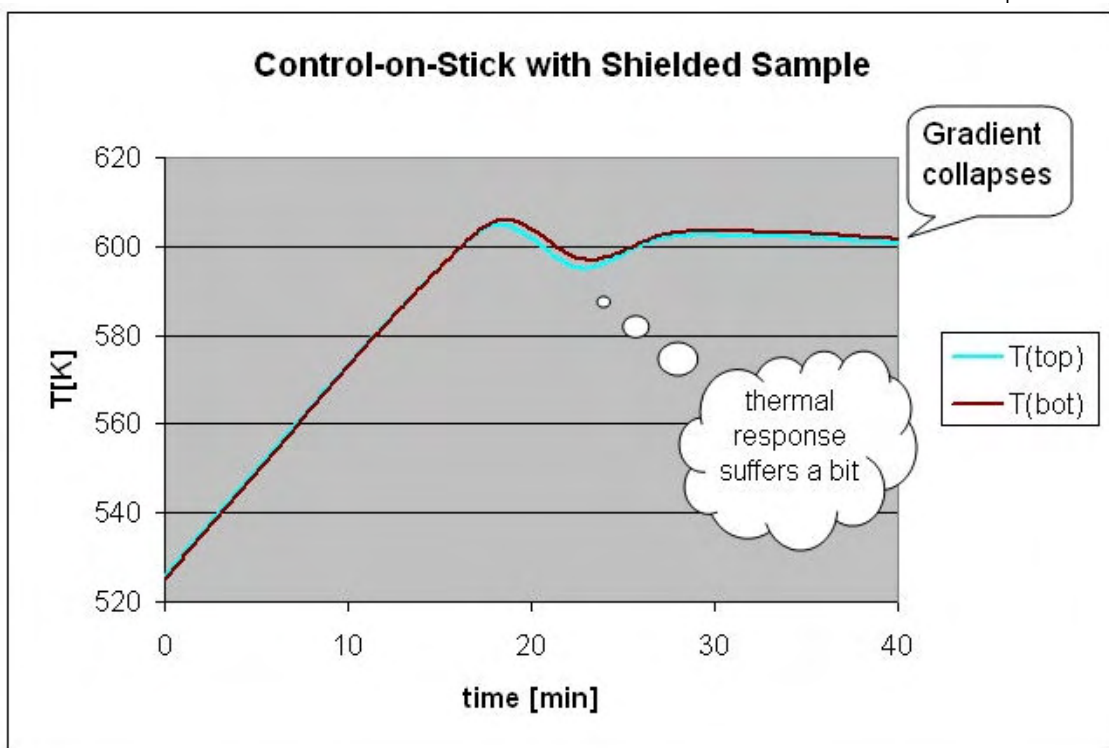
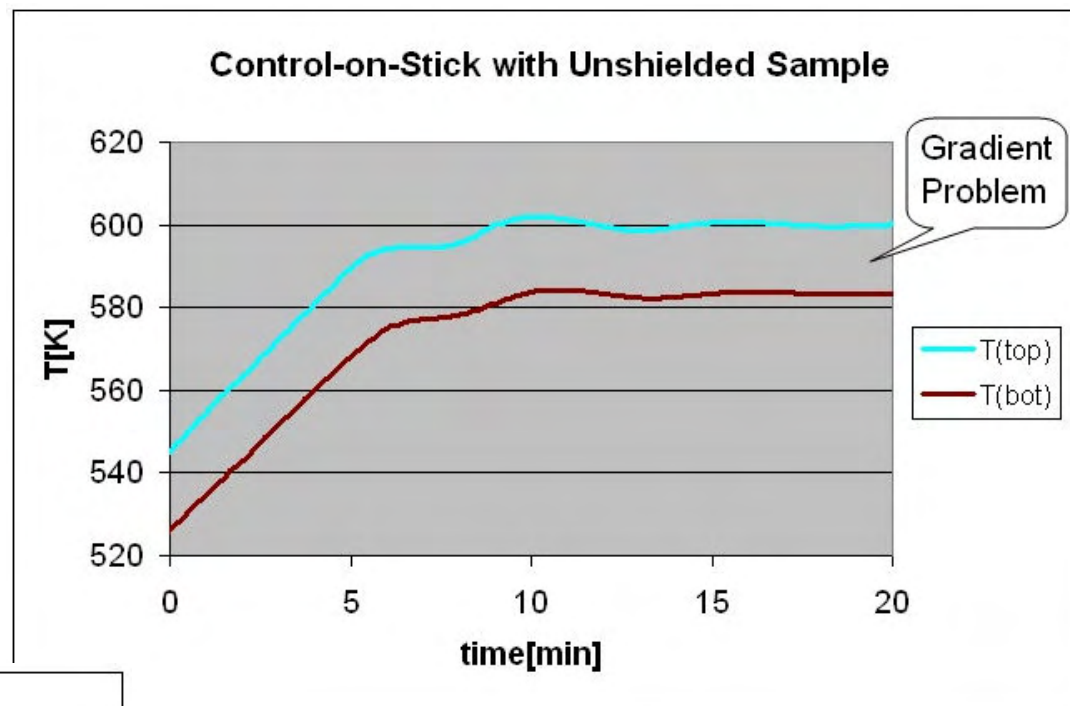

# Design 2 – Hot Stage Displex

- Heat switch
- Sample in vacuum
- Pros
  - Simple
  - Great range
- Cons
  - Delicate interface

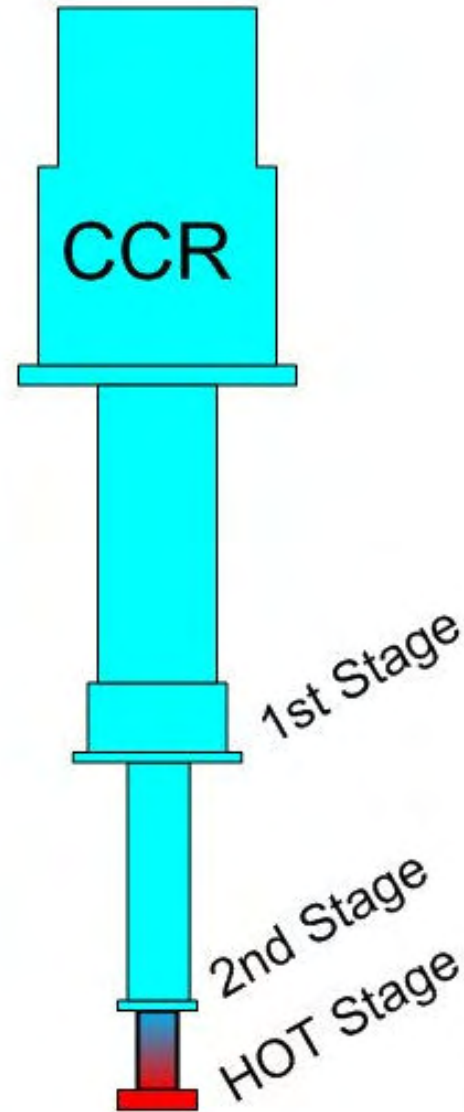

# ARS Hot Stage Displex

Manufacturer: Advanced Research Systems

Range: 5 K to 800 K \*

\* see ORNL experience

Thermometry: T/C's & Pt-RTD

50 Ohm heater

Sample Space: bottom load

## ORNL Experience

Debug & commission at HFIR (2005)

Good CF workhorse

Not used as all-in-one

5 k to 600 K with 50 W heater output

Needs thermometry upgrade



# ARS Hot Stage Displex : Cryo-Data

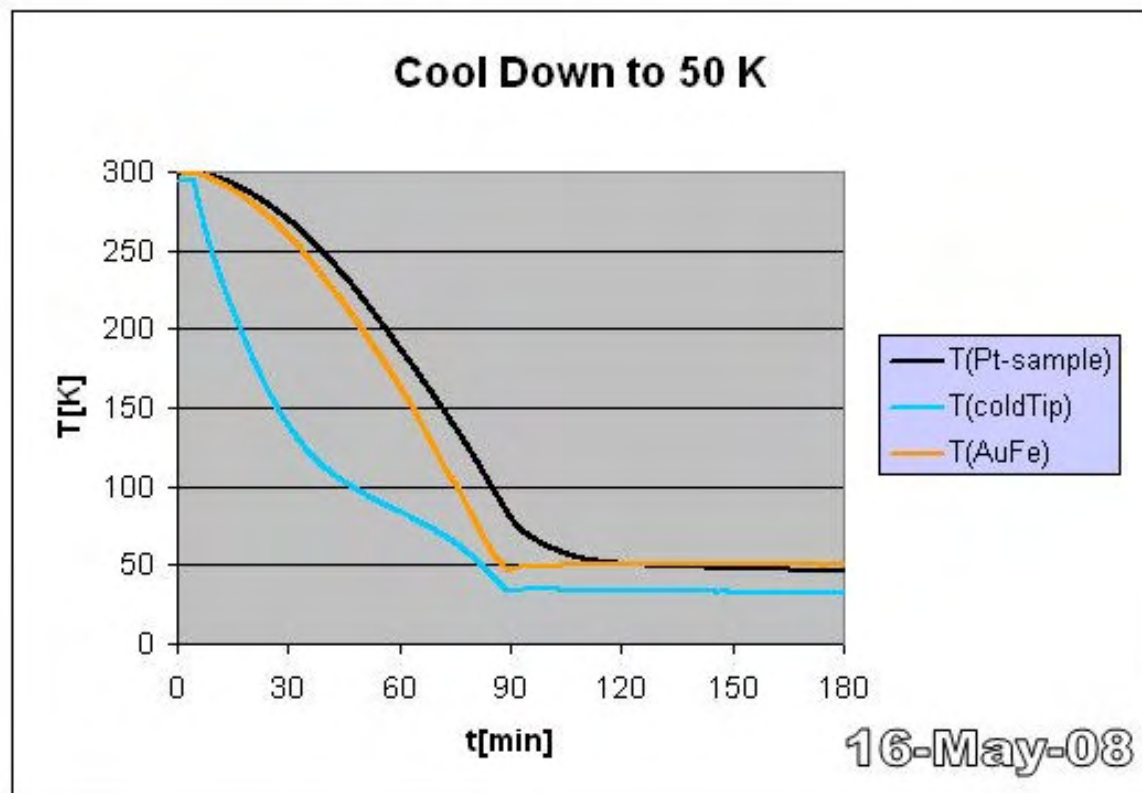

Good cool down and set point response

Sensor offset problem

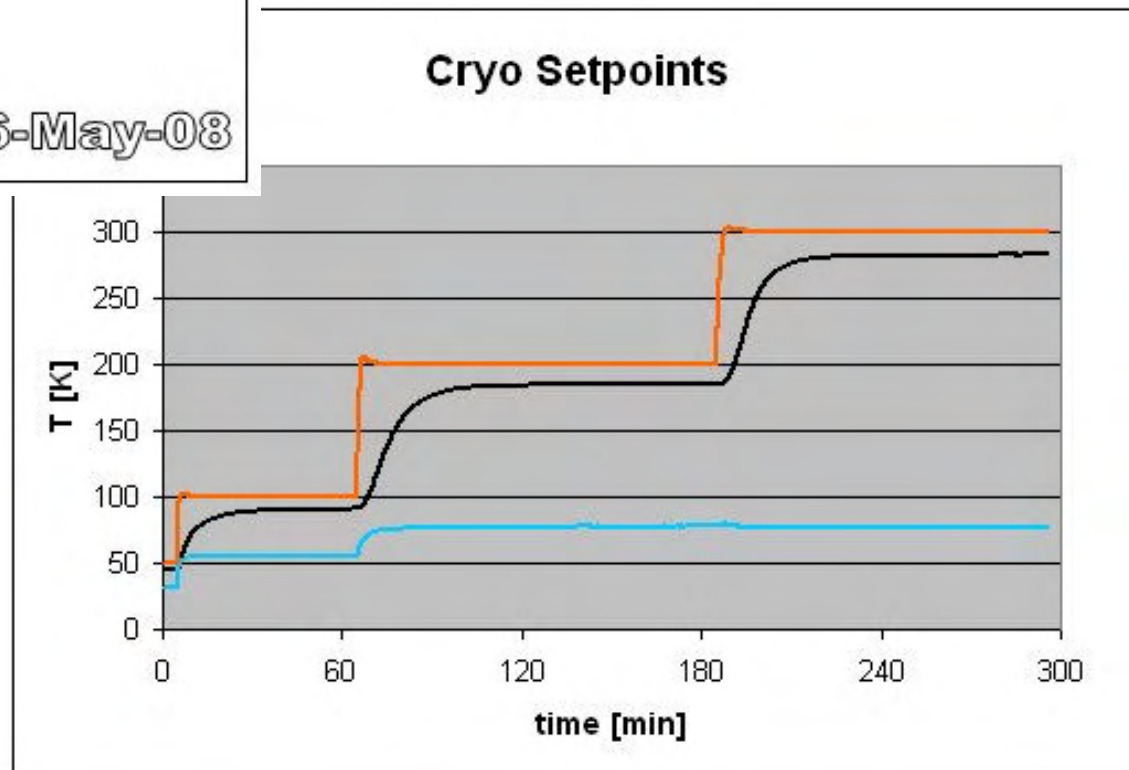



# ARS Hot Stage Displex : HT Data

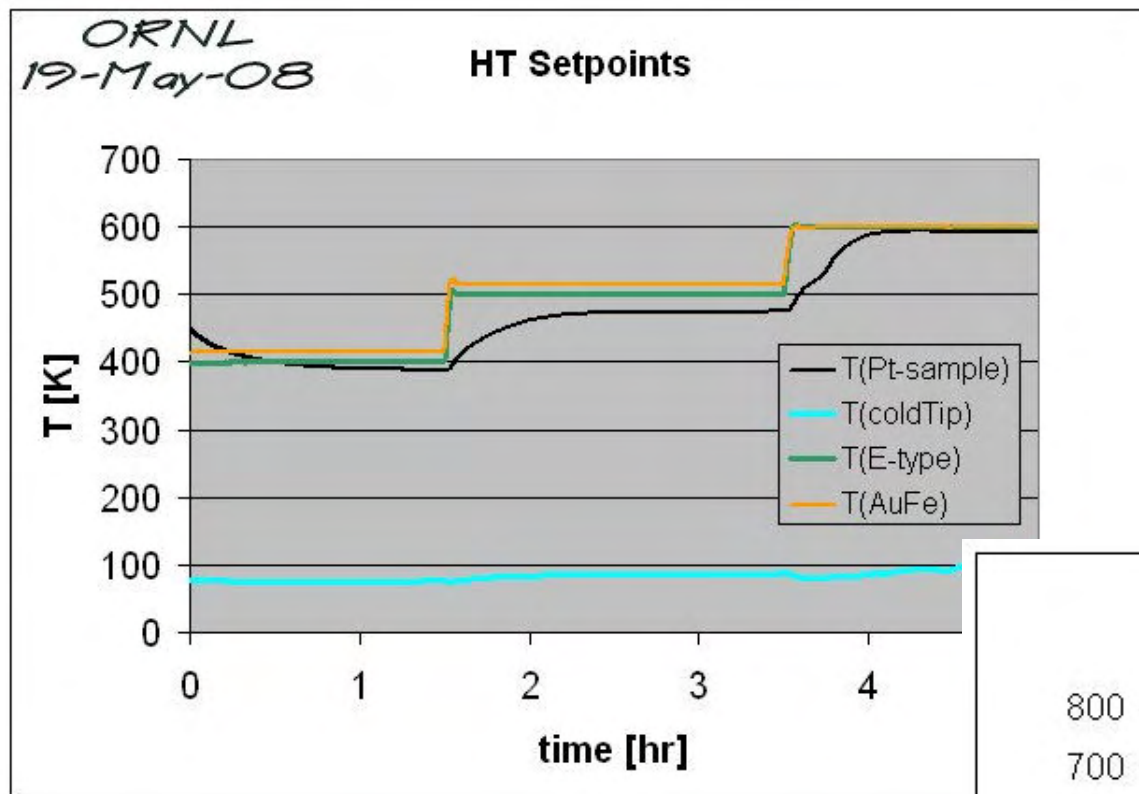

Not bad, except for sensor offset

Not enough power to reach 800 K

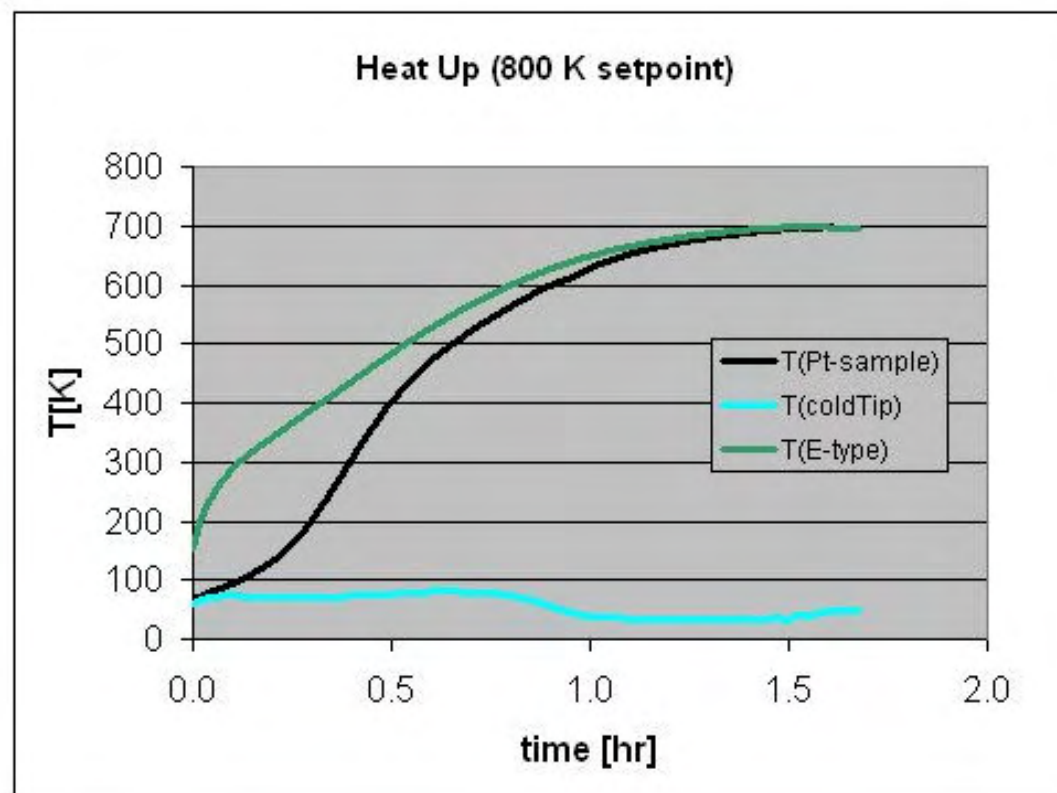

# Design 3 – Hot Exchange Gas - Dry

- **Pros**

- **Sample in helium gas atmosphere**
  - Better temperature uniformity?
- **Easy sample changes**

- **Cons**

- **Hard to make it work as intended**

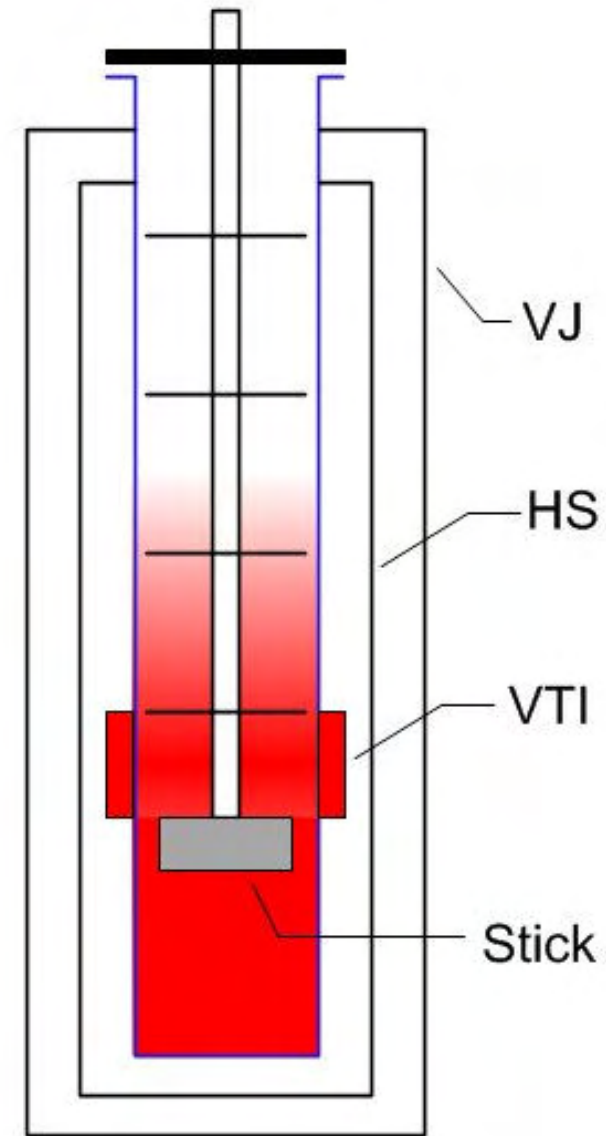

# SNS Hot Exchange Gas CCR Prototype

SNS-designed interface

ARS DE-210 Cryocooler

Range: 20 K to 500 K (rev 0)

4 K to 400 K (rev 1)

Thermometry: Si diode (500 K chip)

50 Ohm heater

Sample Space: 60 mm

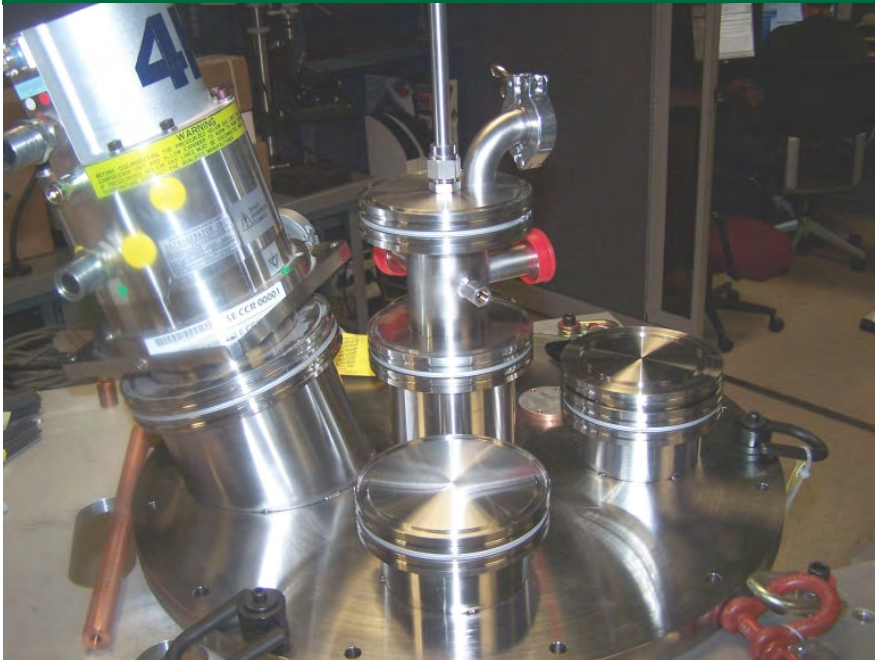
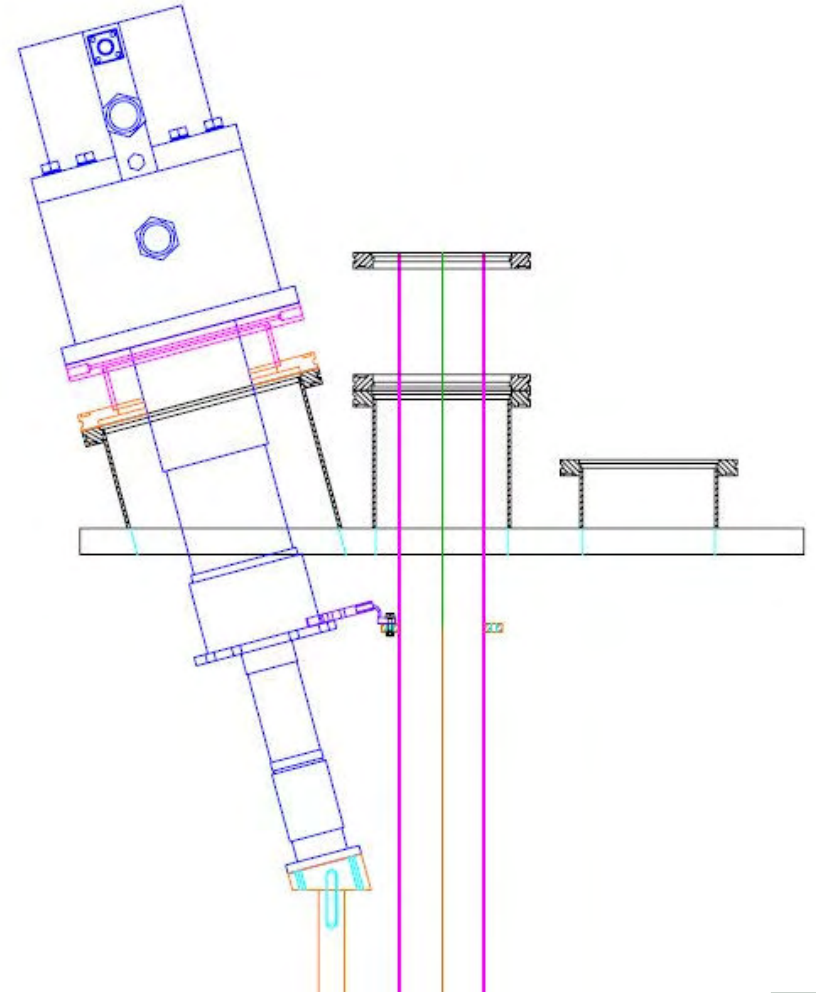

## ORNL Experience

Motivated by needs on BASIS instrument

2007 Design, fabricate & test

2008 Many ups & downs

# SNS Hot Exchange Gas CCR Prototype

## ORNL Experience (cont.)

- Base temperature initially poor
- But VTI reaches 500 K
  - Long thermal link with large delta-T

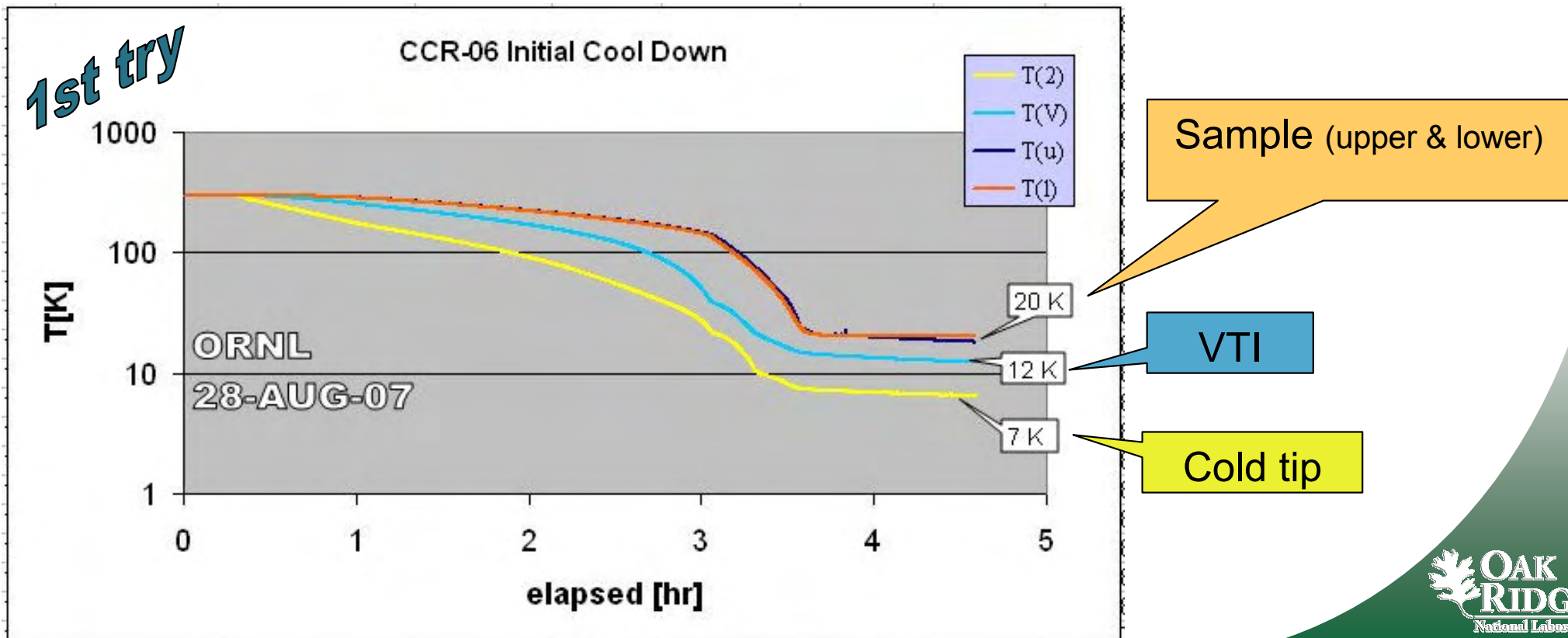

# SNS Hot Exchange Gas CCR Prototype

## ORNL Experience (cont.)

- Control on VTI slow, but does reach 500K
- Dual control helps

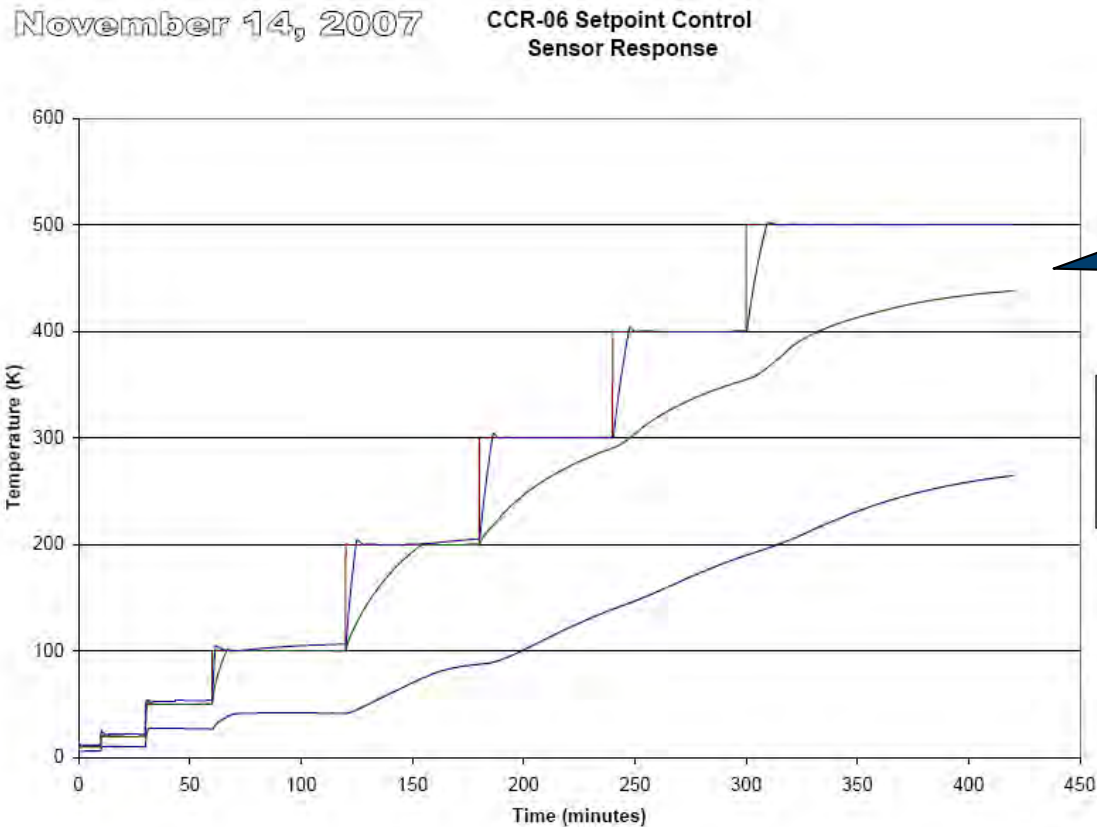

Dual control test to 500K  
Sample stick controls quickly  
VTI sluggish at high-T

# SNS Hot Exchange Gas CCR Prototype

## ORNL Experience (cont.)

- Gradients evaluated

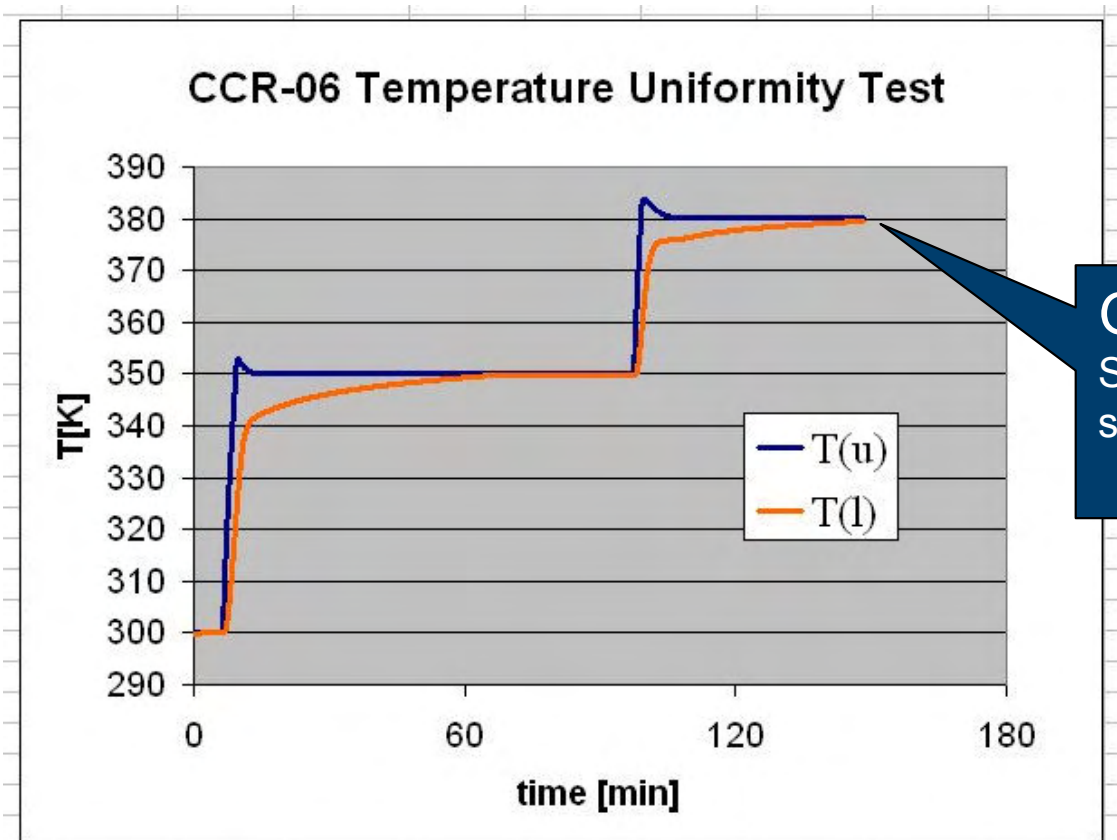

### Gradient Test

Sensors on top and bottom of sample agree (eventually)

# SNS Hot Exchange Gas CCR Prototype

## ORNL Experience (cont.)

- Improved thermal contact and achieved better base temperature

19-Feb-08

Initial Cool Down

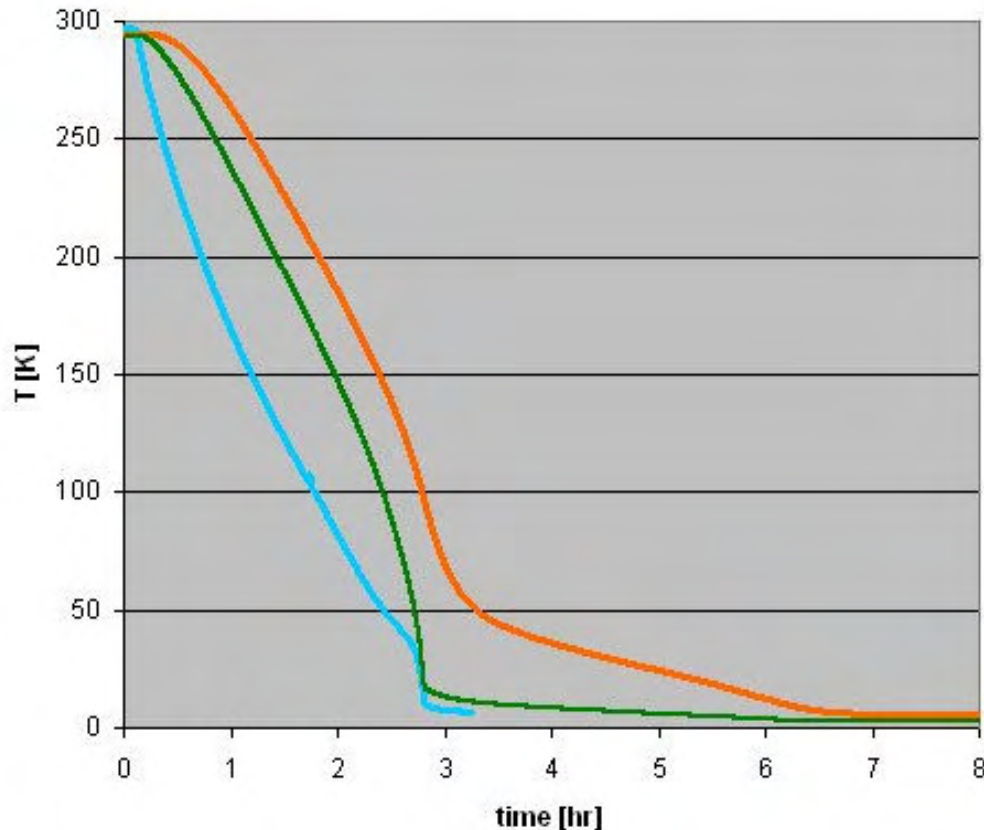

19-Feb-08

Initial Cool Down

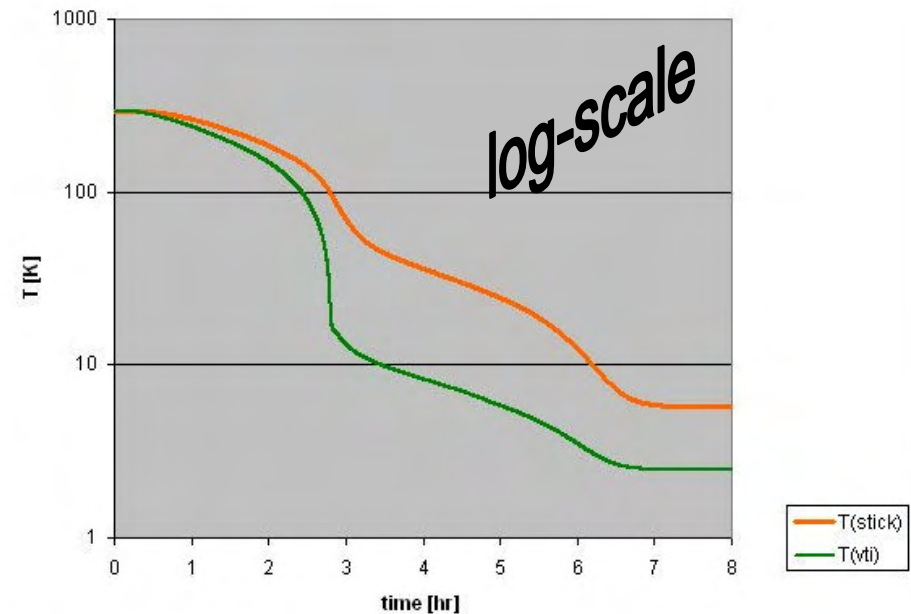

T(coldTip)  
T(stick)  
T(vti)

# SNS Hot Exchange Gas CCR Prototype

## ORNL Experience (cont.)

- Improved thermal contact and achieved better base temperature
  - **But still shows strange behavior: follow-up needed**
- **Upper temperature now limited to 400 K (cold tip begins to get too hot)**
- **Next generation will include heat switch**

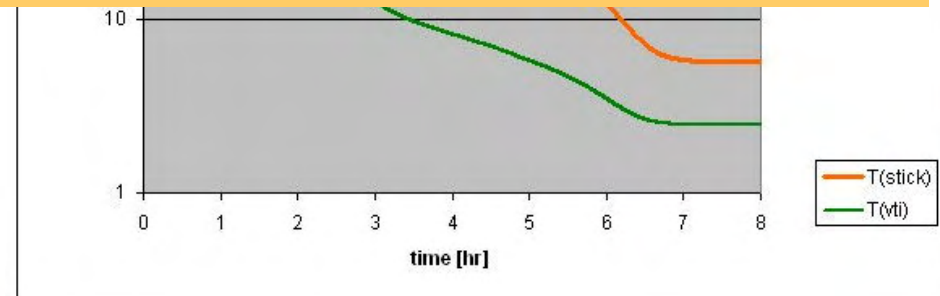
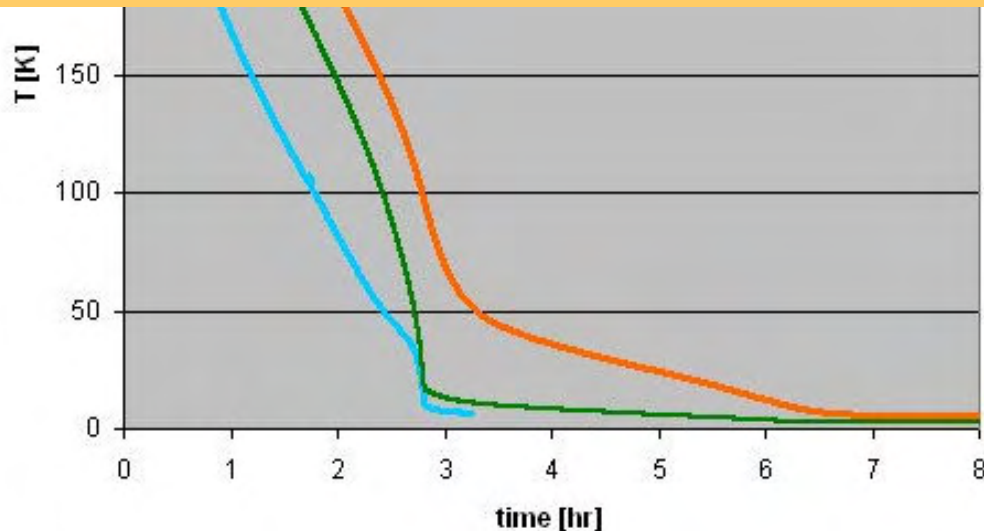



# Design 4 – Hot Exchange Gas - Wet

- Keep exchange gas in tube throughout entire experiment

- Pros

Summer intern project

- Cons

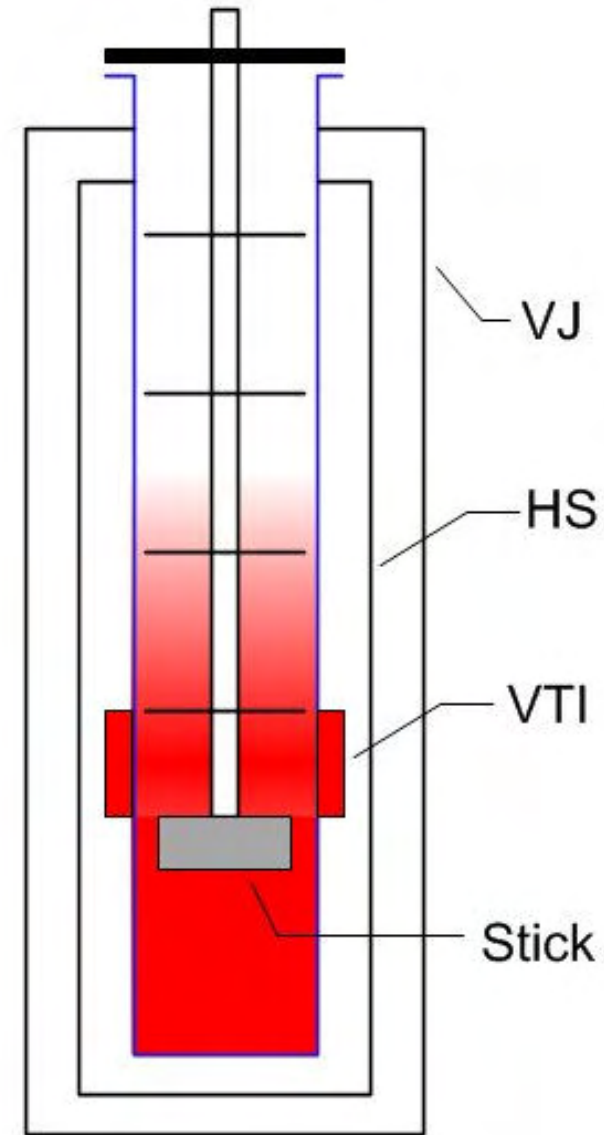

Vacuum jacket – VJ

Heat Shield - HS

Cryogenic variable temperature insert (VTI)

# ILL Orange Cryofurnace

Manufacturer: A. S. Scientific Ltd.

Range: 2 K to 600 K

Thermometry: RhFe

8 Ohm heater?

Sample Space: 70 mm



Summer intern  
project

# Acknowledgements

- **Ken Volin** – for years of help and advice, as he led IPNS sample environment efforts
- **SNS and HFIR Sample Environment Teams**
  - **John Wenzel**: R&D on JANIS automation and SNS hot exchange gas CCR design
  - **Andy Church**: Debugging equipment and optimizing the operating procedures
- **Jonathan Demko** – ORNL cryogenic engineer

# Summary

- We are making steady progress toward optimizing all of our cryofurnaces
  - All should be treated as R&D projects
- Despite difficulties, prototype project is beneficial in the long run

